

W3C Web of Things and Geolocation Discovery

Michael McCool

1 June 2022

Presented to IEEE P2874

Outline

- What is WoT?
 - Applying and extending web standards for IoT
 - Descriptive interoperability: Thing Descriptions
 - Recent Activity
 - Finding Thing Descriptions: Discovery
- Discussion
 - Gaps and Future Work
 - Geolocation Discovery
 - Data: Dynamic and Static
 - Geolocation queries for Discovery
 - Interval queries on actual data?

W3C Web of Things (WoT)

- W3C Working Group goal: Adapting web technologies to IoT
- Already published: Thing Description (TD) metadata format
 - TD describes the available interactions (network API) of a Thing
- New deliverables in progress, including Discovery
 - How does a potential user obtain the TD for a Thing?

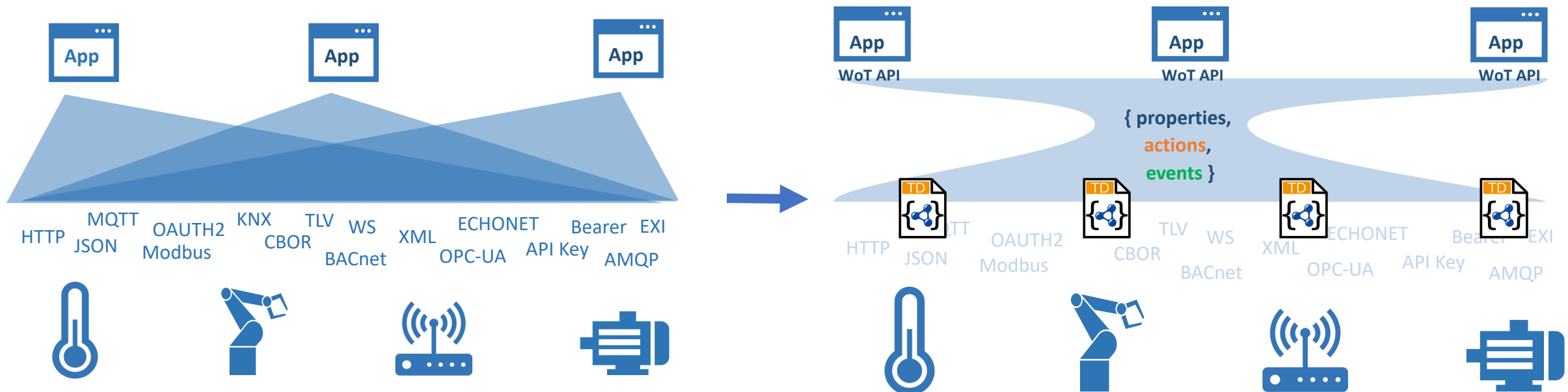

Descriptive Interoperability: TDs

WoT Architecture

- Constraints
 - "Things" must have a TD
 - Must use URIs, IANA media types, etc.
- Thing Description Affordances
 - Describes WHAT the possible choices are
 - Describes HOW to interact with the Thing

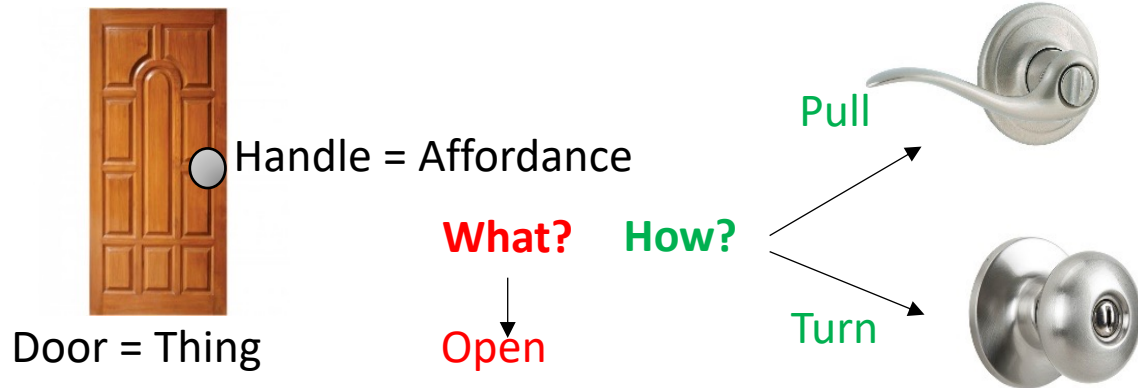

WoT Thing Description (TD)

```

{
  "@context": [
    "https://www.w3.org/2022/wot/td/v1.1",
    { "iot": "http://iotschema.org/" }
  ],
  "id": "urn:dev:org:32473:1234567890",
  "title": "MyLEDThing",
  "description": "RGB LED torchiere",
  "@type": ["Thing", "iot:Light"],
  "securityDefinitions": {
    "default": {"scheme": "bearer"}
  },
  "security": ["default"],
  "properties": {
    "brightness": {
      "@type": ["iot:Brightness"],
      "type": "integer",
      "minimum": 0,
      "maximum": 100,
      "forms": [ ... ]
    }
  },
  "actions": {
    "fadeIn": {
      ...
    }
  }
}
    
```

Usage Patterns Overview

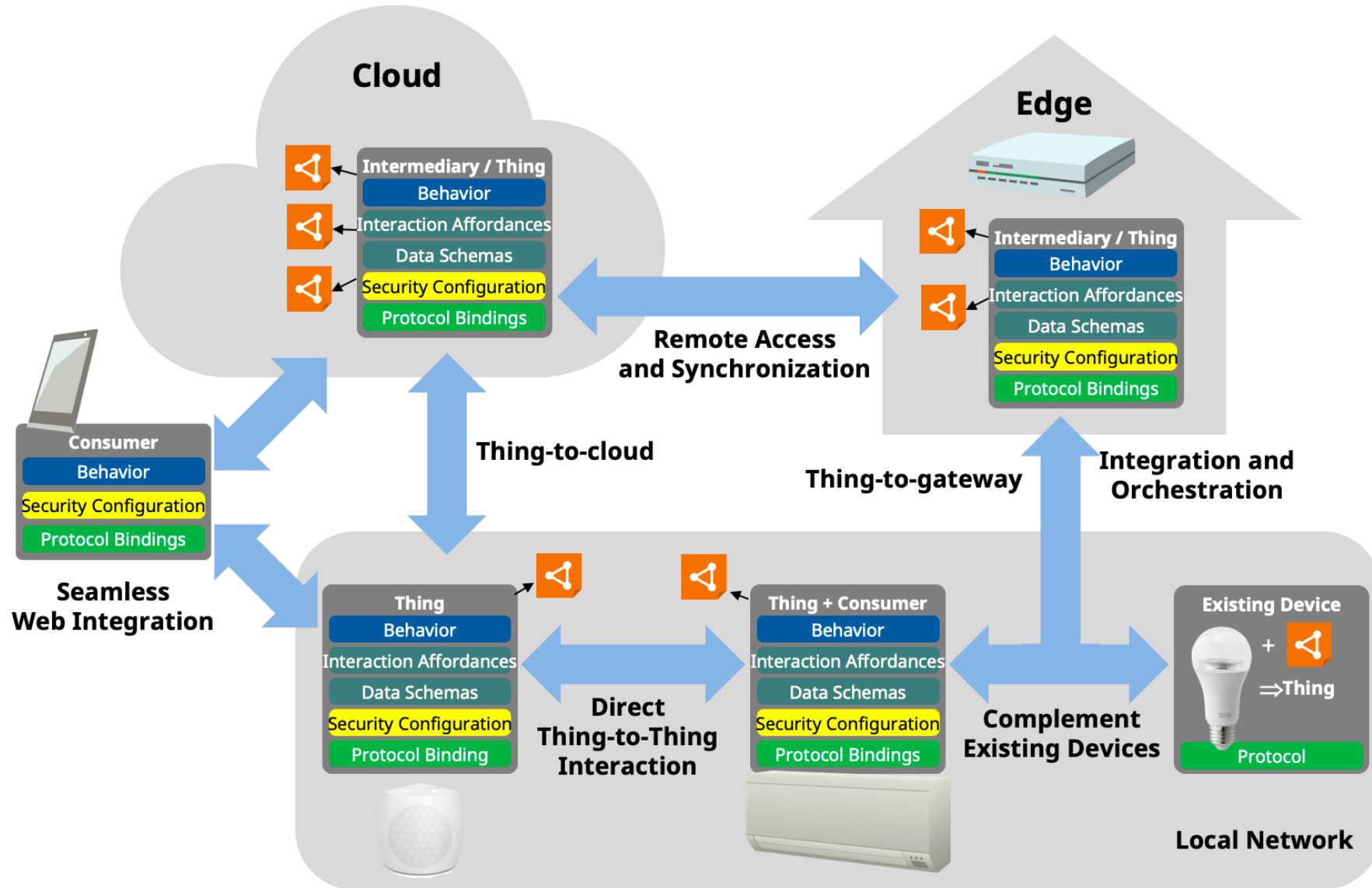

Orchestration

Node-RED/node-gen

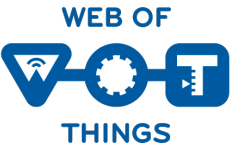
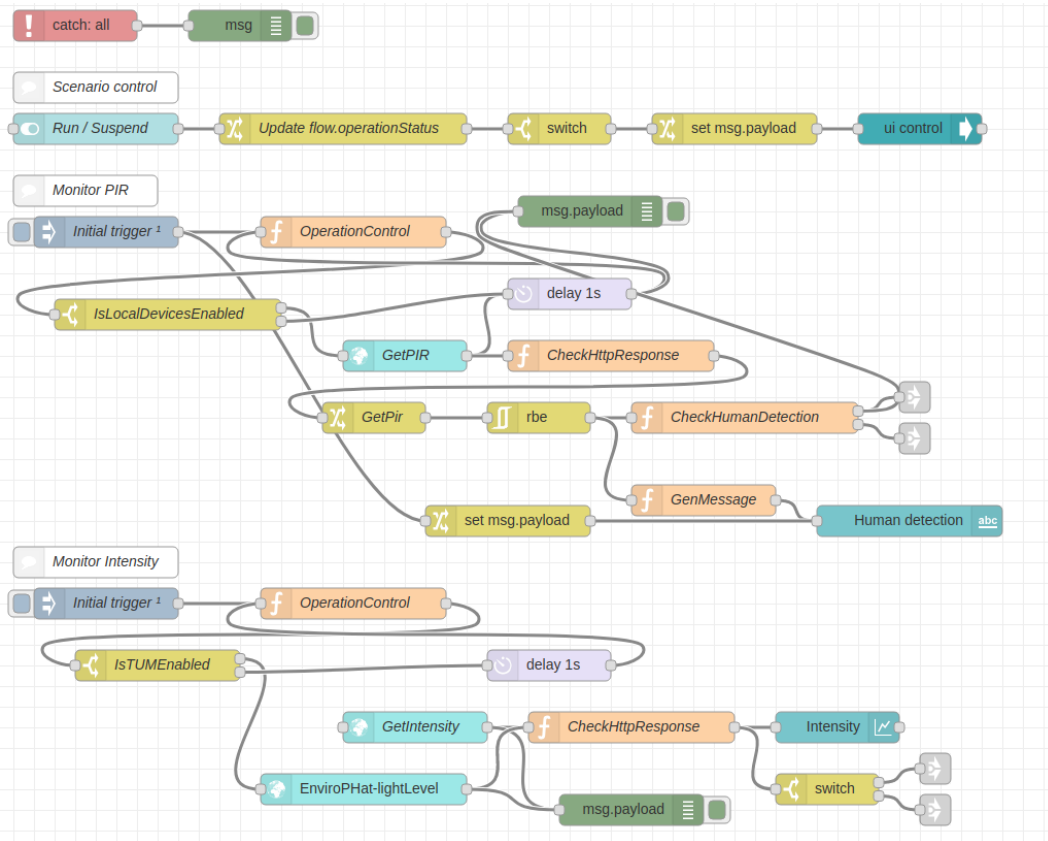

node-wot/Scripting API

```
WoTHelpers.fetch( "coap://localhost:5683/counter" ).then( async (td) => {  
  // using await for serial execution (note 'async' in then() of fetch())  
  try {
```

```
    const thing = await WoT.consume(td);  
    console.info( "=== TD ===" );  
    console.info(td);  
    console.info( "======" );
```



```
    // read property #1
```

```
    const read1 = await thing.readProperty( "count" );  
    console.info( "count value is" , await read1.value());
```

```
    // increment property #1 (without step)
```

```
    await thing.invokeAction( "increment" );  
    const inc1 = await thing.readProperty( "count" );  
    console.info( "count value after increment #1 is" , await inc1.value());
```

```
    // increment property #2 (with step)
```

```
    await thing.invokeAction( "increment" , { 'step' : 3 });  
    const inc2 = await thing.readProperty( "count" );  
    console.info( "count value after increment #2 (w/ step 3) is" , await inc2.value());
```

```
    // decrement property
```

```
    await thing.invokeAction( "decrement" , undefined, {  
      formIndex: getFormIndexForDecrementWithCoAP(thing);  
    });  
    const dec1 = await thing.readProperty( "count" );  
    console.info( "count value after decrement is" , await dec1.value());
```

```
  } catch(err) {  
    console.error( "Script error:", err);  
  }
```

```
}).catch( (err) => { console.error( "Fetch error:", err); });
```

Deliverables

New/Updated Normative Documents:

- Architecture 1.1: <https://github.com/w3c/wot-architecture>
- Thing Description 1.1: <https://github.com/w3c/wot-thing-description>
- Discovery: <https://github.com/w3c/wot-discovery>
- Profiles: <https://github.com/w3c/wot-profile>

New/Updated Informative Documents:

- Binding Templates: <https://github.com/w3c/wot-binding-templates>
- Scripting API: <https://github.com/w3c/wot-scripting-api>
- Use Cases and Requirements: <https://github.com/w3c/wot-usecases>

Community Resources:

- Web Site: <https://www.w3.org/WoT/>

Recent Activity

- Upcoming Plugfest/Testfest: March 14-18
 - <https://github.com/w3c/wot-testing/tree/main/events>
- New Commercial Usages
 - Takenaka Construction – Smart Building Information Management systems
 - Netzo – IoT dashboards and device management
- Directory Implementations
 - WoT Hive, LogiLab (SPARQL based), Fraunhofer LinkSmart
- IETF Relationships: JSON Path, CoreRD, COSE/JOSE, ASDF
- Under Discussion:
 - Geospatial data, Embedded JSON Signatures
 - New Charters/New Deliverables

Applications



<https://www.takenaka.co.jp/news/2021/05/02/>

Takenaka Corporation

- CGLL Platform - BIM



<https://new.siemens.com/global/en/products/buildings/automation/desigo.html>

<https://www.evosoft.com/en/digitalization-offering/saywot/>

Siemens

- Desigo CC – BIM
- Say WoT!

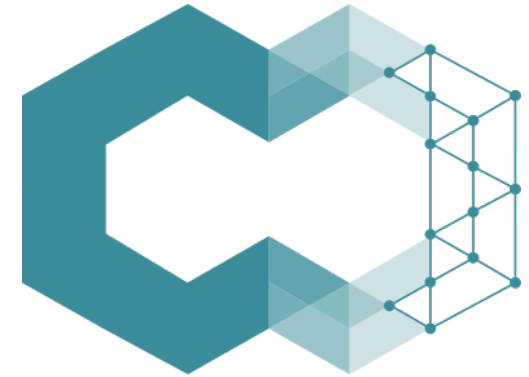

ditto

<https://www.eclipse.org/ditto/2022-03-03-wot-integration.html>

Bosch

- Eclipse Ditto - Digital twin

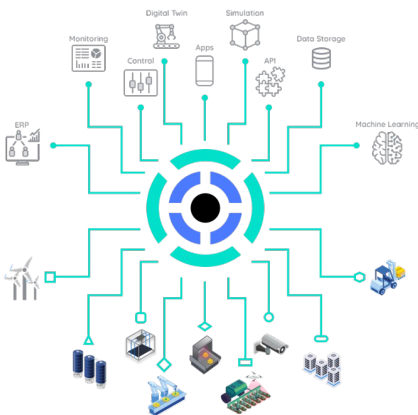

<https://netzo.io/>

Netzo

- IoT Data Hub
- Dashboards

Gaps and Future Work

- GIS Integration
 - Geospatial data and discovery
- Data Management
 - Digital Twins and shadows
 - Event notifications
 - Historical data
- Security
 - Key provisioning and onboarding
 - Secure LAN access
 - Proxy services
 - Access control and ad-hoc sharing
 - MUDS
- Accessibility
 - Sensory modality mapping
 - Textual/descriptive interfaces
 - Service location
 - Mobility services
- Advanced Use Cases
 - Transportation
 - Logistics
 - Distributed energy management
 - AR visualization
 - Analytics integration e.g. for health and safety monitoring

Discovery

Goal:

Obtain TD of interest

- Not limited to local network
- Scalable to many TDs
- Need to preserve privacy

Architecture:

- Phased access:
 1. Introduction: open
 2. Exploration: controlled access
- Introduction mechanisms
 - Direct, WK, DNS-SD, CoRE-RD, DID
- Exploration mechanisms
 - TD Server, Self, Directory
- Directories searchable via
 - JSON Path (IETF RFC pending)
 - XPath 3.1
 - SPARQL

Discovery

Introduction Mechanisms

Direct



Well-Known URIs



DNS-Based Service Discovery

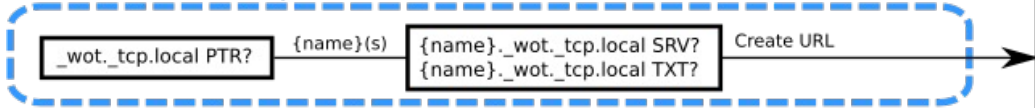

CoRE Link Format and CoRE Resource Directory

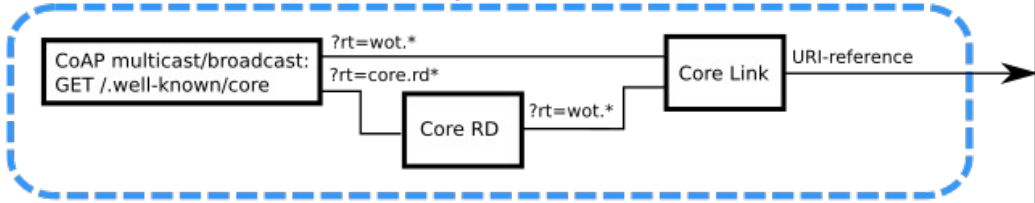

DID Documents



URLs

Auth

Exploration Mechanisms

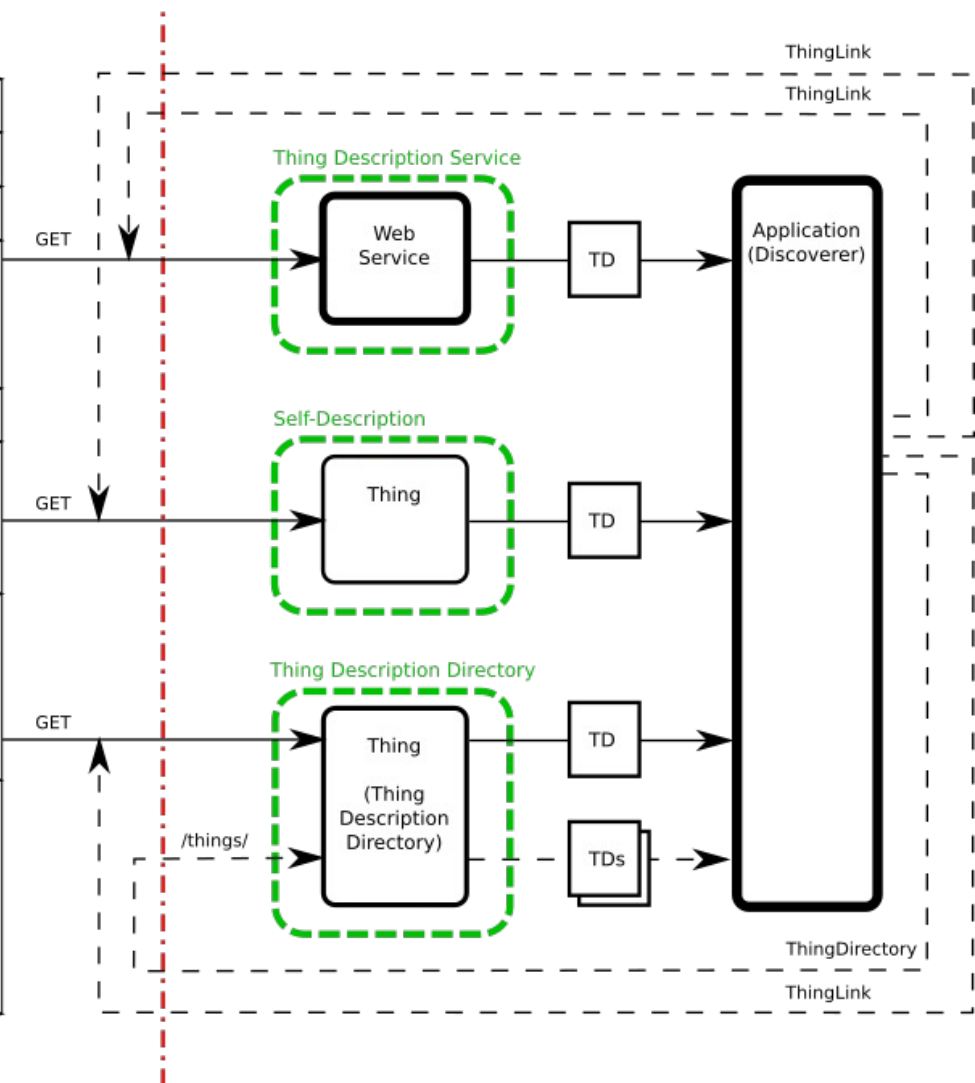

Discovery

- Possible future work:
 - Encode static geospatial data in Thing Descriptions
 - Provide ontologies for dynamic geospatial data
 - Index Things by location in TD Directories
 - Provide geolocation filters in Introduction mechanisms
 - e.g. geolocation filters in DNS-SD
 - Discover Things using geospatial queries
 - "find all Things within 100m of lat 49.2803175 long -123.1286623"
 - "find all HVAC sensors in Room 101 of Sheraton Wall Vancouver"
 - Both "quantitative" and "qualitative" locations important
 - Also store sensor data and search based on interval queries
- See:
 - [Geolocation proposal](#)
 - [Discussion of next WoT charter](#)

Resources and Contacts

<https://www.w3.org/WoT>

Dr. Michael McCool

Principal Engineer

Intel

Technology Pathfinding

michael.mccool@intel.com

Dr. Sebastian Kaebisch

Senior Key Expert

Siemens

Technology

sebastian.kaebisch@siemens.com