



WoT.JS - Web of Things Framework



What is WoT.JS framework ?

- WoT.js is an open source Javascript framework for **WoT(Web of Things) applications on OSHW(Open Source Hardware) using Node.js**
- It provides a simple, yet powerful way to **create WoT application that incorporate multiple, different hardware devices** at the same time.
- It provides the **RESTful architecture** based **sensor/actuator access interfaces** and integrate with various **IoT/WoT protocols(HTTP, MQTT, CoAP, WebSocket)** easily.
- You can get the tons of benefits from node.js application environment - easy & fast development, **using many kinds of JS libraries and Web technologies.**

Architecture model of WoT.JS framework

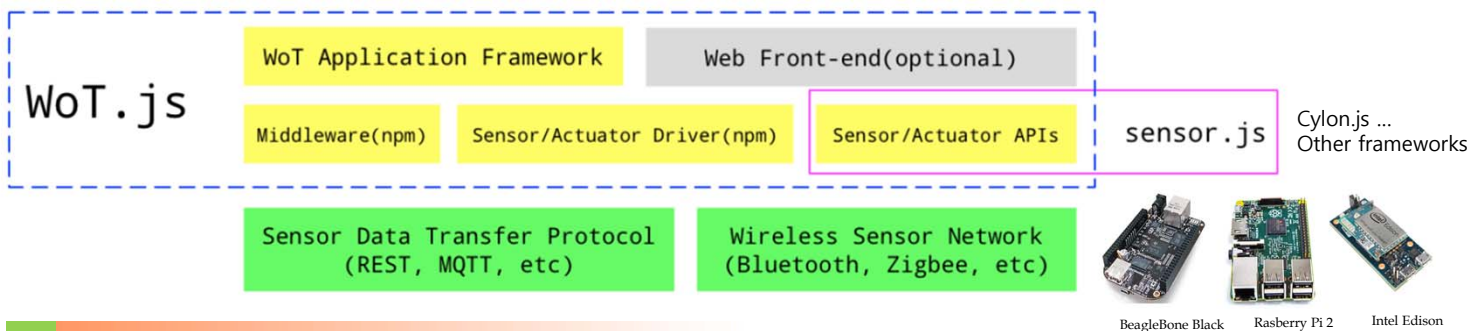

Interaction and Interface models

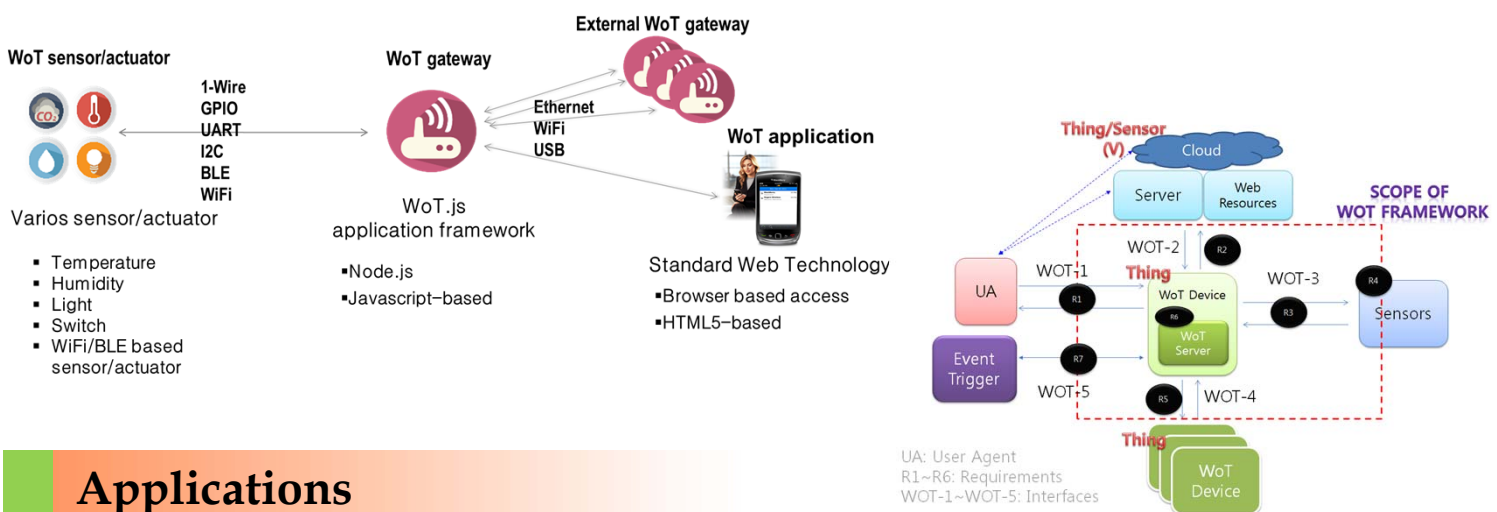

Applications

- OSHW based **IoT/WoT applications**(**smart home, healthcare, smart industry, smart agriculture, wearable ...**) development and prototyping